

TBX FLANGES

FLANGE DIN 2576

USO: En aplicaciones de piping, para conectar extremos de cañerías, accesorios y/o equipos.
PROPIEDADES: Adaptabilidad a temperaturas extremas, excelente soldabilidad.
DIAMETROS: Desde 1/2" hasta 20"
CARA: RF (Raised Face)

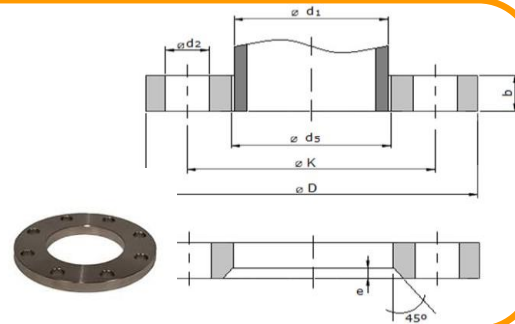

DN	B r i d a			Diám. Int. d5 mm.	Tornillos			Peso Aprox. Kg/Und.
	D	K	b		Número	Rosca	d2	
	mm.	mm.	mm.					
10	90	60	14	18	4	M12	14	0.604
15	95	65	14	22	4	M12	14	0.67
20	105	75	14	27.5	4	M12	16	0.936
25	115	85	14	34.5	4	M12	16	1.11
32	140	100	18	43.5	4	M16	18	1.82
40	150	110	18	49.5	4	M16	18	2.08
50	165	125	18	61.5	4	M16	20	2.73
65	185	145	18	77.5	8	M16	20	3.16
80	200	160	18	90.5	8	M16	20	3.6
100	220	180	18	116	8	M16	22	4.39
125	250	210	18	141.5	8	M16	22	5.41
150	285	240	22	170.5	8	M20	24	7.14
200	340	295	22	221.5	8	M20	24	9.27
250	395	350	22	276.5	12	M20	26	11.8
300	445	400	22	327.5	12	M20	26	13.6
350	505	460	22	359.5	16	M20	28	20.4
400	565	515	26	411	16	M24	32	27.5
450	615	565	26	465.5	20	M24	38	35.6
500	670	620	26	513.6	20	M24	38	41.1